

2012 FISHING CATALOGUE

GUIDING
THE FISHING
INDUSTRY - *Since 1997*



引导渔具行业

METAL PRODUCING CO.,LTD

——創始于1997年，專業致力於漁竿配件的開發和生產

威海兴泰金属制造有限公司 Add: 中国山东省威海市经区北山村北 Tel: 0631-5993569 5995569
Fax: 0631-5992569 Http: //www.whxingtai.com E-mail: sea_guide@vip.163.com P.C: 264205



SEA-GUIDE

METAL PRODUCING CO.,LTD



Enjoying the nature's present
-----*far from blatant city, coming near the nature.*

Enjoying the nature's present
-----*far from blatant city, coming near the nature.*

Dancing with fish, enjoying fishing carefreely.

SEA-GUIDE will go to great lengths to improve the quality of fishing rod kits,

And you will not have the misgivings about the quality of the fishing rods.

盡享大自然的饋贈

----- 遠離城市喧囂，投入自然的懷抱。

与鱼儿共舞，尽享悠然的垂钓。

兴泰人会一直竭尽全力，

完善钓具配件的品质，

让您在垂钓过程中无后顾之忧。



目前可提供电镀颜色 / Currently available plating colours

Samples (样品)	Category (种类)	Code (代码)	Instruction (备注)
	White(白色)	Be omitted (代码省略)	Chromeplated(镀铬)
	Frosted white(消光白色)	TW	Nickle-plated+Chromeplated(镀镍+镀铬)
	Black(黑色)	B	Electrophoresis(电泳)
	Frosted-black(消光黑)	TB	Electrophoresis(电泳)
	Gold(金色)	G	24Kgold-plated+overcoat varnish (24K金+罩光清漆)
	Light gold(浅金)	C	14Kgold-plated+overcoat varnish (14K金+罩光清漆)
	Gun-smoke(枪色)	U	Gun-color plating+overcoat varnish (电镀枪色+罩光清漆)
	Frosted gun-smoke(消光枪色)	TU	Frosted gun-color plating+overcoat varnish (电镀消光枪+罩光清漆)
	Pearl nickel(珍珠镍)	N	Pearl nickel plating(镀珍珠镍)

目前可提供氧化颜色 / Currently available oxidizing colours

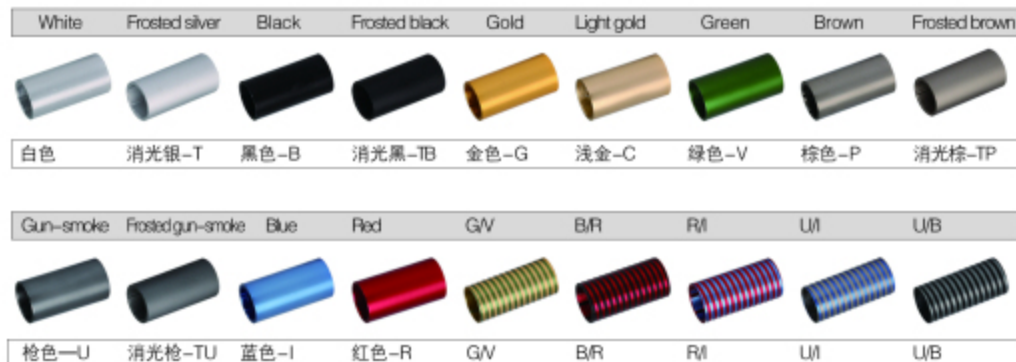

目前可提供瓷环种类 / All kind of the ceramic rings

NEW

LC-RING

Colour (颜色)	BLACK
Material (材质)	Si3N4
Weight (比重)	3.2(g/cm ³)
Hardness (硬度)	2200-2400(H.kg/mm ²)

D-1 RING

Colour (颜色)	Stainless steel
Material (材质)	电镀色任选

TS-RING

Colour (颜色)	BLACK
Material (材质)	TiO2
Weight (比重)	4.25(g/cm ³)
Hardness (硬度)	900-1100(H.kg/mm ²)

NTS-RING

Colour (颜色)	BLACK
Material (材质)	ZrO2
Weight (比重)	5.85(g/cm ³)
Hardness (硬度)	1600-1800(H.kg/mm ²)

FLTS-RING

Colour (颜色)	BLACK
Material (材质)	Special TiO2
Weight (比重)	4.25 (g/cm ³)
Hardness (硬度)	900-1100(H.kg/mm ²)

FLES-RING

Colour (颜色)	BROWN
Material (材质)	Al2O3
Weight (比重)	3.62(g/cm ³)
Hardness (硬度)	1200-1400(H.kg/mm ²)

O-RING

Colour (颜色)	GREEN
Material (材质)	TiO2
Weight (比重)	3.86(g/cm ³)
Hardness (硬度)	900-1100(H.kg/mm ²)

SD-RING

Colour (颜色)	BLACK
Material (材质)	Special TiO2
Weight (比重)	4.25 (g/cm ³)
Hardness (硬度)	900-1100(H.kg/mm ²)

LTS-RING

Colour (颜色)	BROWN
Material (材质)	Al2O3
Weight (比重)	3.62(g/cm ³)
Hardness (硬度)	1200-1400(H.kg/mm ²)

A-RING

Colour (颜色)	BROWN
Material (材质)	Al2O3
Weight (比重)	3.62(g/cm ³)
Hardness (硬度)	1200-1400(H.kg/mm ²)

LG-RING

Colour (颜色)	GREEN
Material (材质)	TiO2
Weight (比重)	3.86(g/cm ³)
Hardness (硬度)	900-1100(H.kg/mm ²)

目前可提供瓷环颜色 / Currently available ring's colours

COLOR	RING	RING CODE(镀色瓷环代码)
GOLD(金色)		TS(ID-1) LTS(LTS-1) LS(LS-1)
GUN-SMOKE(枪色)		TS(ID-2) LTS(LTS-2) LS(LS-2)
SLIVER(银色)		TS(ID-3) LTS(LTS-3) LS(LS-3)
BLUE(蓝色)		TS(ID-4) LTS(LTS-4) LS(LS-4)
IRIDE-SCENCE(五彩)		TS(ID-5) LTS(LTS-5) LS(LS-5)
ROSE GOLD(玫瑰金)		TS(ID-6) LTS(LTS-6) LS(LS-6)

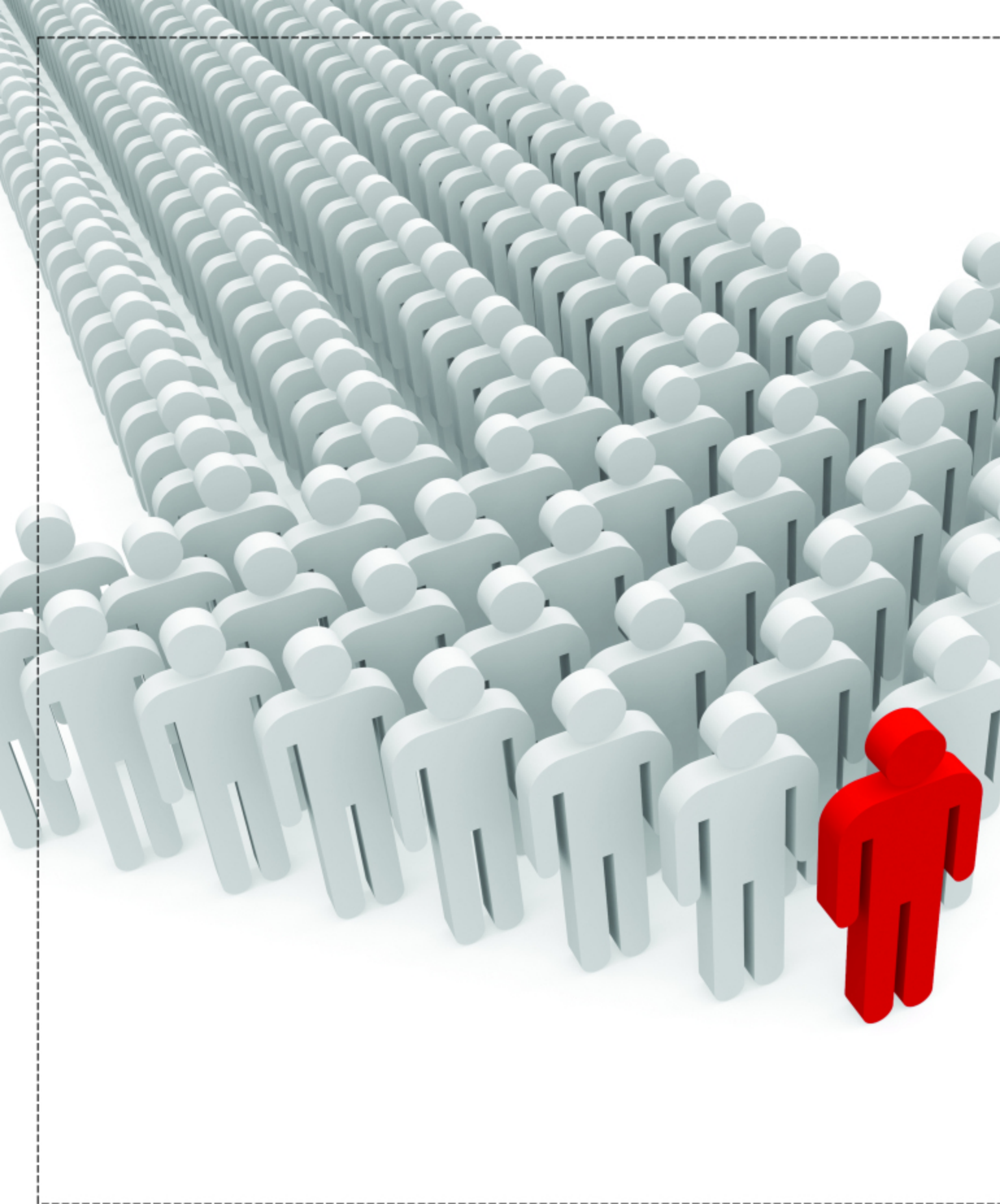

PLATING COLOURS
>>> Page.01-02

GUIDE
>>> Page.04-22

REELSEAT
>>> Page.23-31

ALUMINIUM REEL SEAT
>>> Page.32-38

WEIHAI SEA-GUIDE METAL PRODUCING CO.,LTD

was started on July 1997 the main product is fishing tackle kit product. In the initial stage, we had establishment a basic operation way to increase the product, pursuing the product quantity, perfect product category, using superior quality, perfect service for satisfy the customer's need. 997 the main product is fishing tackle kit product. In the initial stage, we had establishment a basic operation way to increase the product, pursuing the product quantity, perfect product category, using superior quality, perfect service for satisfy the customer's need.













2012 NEW STYLE **Introduction**

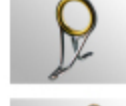
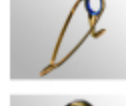











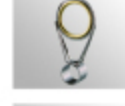

WEIHAI SEA-GUIDE METAL PRODUCING CO.,LTD was started on July 1997 the main product is fishing tackle kit product. In the initial stage, we had establishment a basic operation way to increase the product, pursuing the product quantity perfect product category using superior quality, perfect service for satisfy the customer's need. Since then, our company always insist the operate way, absorb the technique, management method of abroad forerunner, pass by own research, and work hard, under the help of our customer, continuously increase the one self's production ability to develop the ability of production scale with technique at gradually extend. We xingtai person will solidly together, keep the stability of the product quantity, after sales service's perfect, and pricing rationality of sale match the customer's need. We are always in the effort, we will do our best. Thank all friends for supporting us consistently!

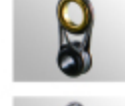



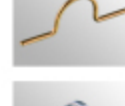

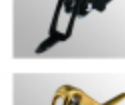





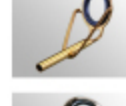

威海兴泰金属制品有限公司始创于1997年7月，主要生产经营渔具用配套产品，创建初期，公司制定基本经营方针为“提高产品档次，追求产品质量，完善产品种类，用优质的产品，完善的服务满足客户需求”。创建以来，公司一直坚持经营方针，吸取国外先进技术和方法，经过自己的研究，摸索，在广大客户的帮助下，不断提高自身的生产力和技术开发能力，生产规模也逐步扩大，我们全体兴泰人将会团结在一起，保持产品质量的稳定性，售后服务的我们一直在努力，我们做的会更好！感谢所有朋友对我们一贯的支持和信任！

GUIDE

	XY 03
	OS 04
	OY 04
	NOY 04
	YGS 05
	OH 05
	HL 05
	MHL 06
	L 06
	B 06

	T 07
	OB 07
	U 07
	LR 08
	XB 08
	XT 08
	XE 09
	XR 09
	AG 09
	BG 10
	MK 10
	XM 10
	SV 10
	Y 11

	OSFR 11
	HM 11
	SM 12
	WDM 12
	MV 12
	WF 13
	WM 13
	WFM 13
	S'SG 14
	ZHOOK 14
	HOOK 14
	H.HOOK 14
	NRHG 15
	RHG 15
	XPHG 15

	ICFG 15
	XSFG 15
	XL 16
	V 16
	XS 17
	SL 17
	L 18
	S 18
	U 19
	LR 19
	AT-1 19
	AT-2 19
	MK 20
	XR 20
	BT 21













	FWT 21
	NRHT 21
	DRHT 21
	RHT 22
	XPHT 22
	IHFG 22
	ITSG 22
	ITHT 22
	ITST 22

REEL SEAT

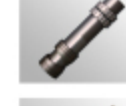
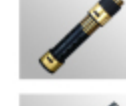
	XCKS 23
	XKS 23
	XIS 23
	XCIS 23
	DNPS 24

	XCHS 24
	XHS 24
	XCJS 24
	XJS 25
	DPS 25
	NPS 25
	TPS 26
	ECS 26
	IPSA 26
	IPSB 27
	PS 27
	XPS 27
	NPLS 27
	XPLS 28
	SPLS 28

	SECS 28
	STPS 29
	TCS 29
	XES 29
	XCES 30
	PSS 30
	XDS 30
	XCDS 30
	XCS 31
	XGS 31
	XCGS 31
	PBS 31
	TIFS 33
	UFS 33
	IFS 33

	CFS 34
	TFS 34
	SWS 34
	AFS 34
	DAS 35
	DWAS 35
	MBS 35
	DAPS 36
	MHS 36
	DWPS 36
	HDPS 36
	后堵 37
	五金件 37

Remark:
The unit of "H,L,L,L" is "mm".
The unit of "s/w,t/w" is "g".
备注:
"H,L,L,L"等的计量单位为毫米(mm)
"S/W,T/W"的计量单位为克(g)

XY

NEW



SIZE	H	L	L1
6	11.5	14.5	7.5
8	14.5	17	8.5
10	18	21	10.5
12	22	26	13
16	27	29	13.5
20	34	32	15
25	43	40	20
30	51	48	21

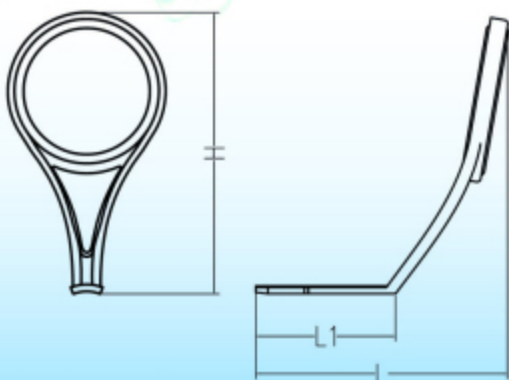

1. 拉伸处理, 增加了导架圈与导线环外壁的连接面积, 不易碎环, 掉环, 提高了导线环的固定强度。
2. 改变支架腿的弯折角度, 增加了承受弯曲力矩的能力。
3. 脚部的防滑设计, 减轻了整个支架的重量, 将脚部长度变短, 而又不影响绑紧力。

1. The frame encasing the ring is broadrimmed, so it can effectively avoid the ring broken off.
2. Changing the angle of the guide to improve the flexural ability.
3. Skidproof design.



WEI HAI SEA-GUIDE METAL PRODUCING

OS



WO-TUOSLGG WO-UOSLTSG-1 WO-GOSLTSG-4 WO-OSTSG

SIZE	H	L	L1	SW	TW
4	7	9	6.5		
5	10.5	9	6	0.10	0.06
6	11	12	8	0.12	0.07
7	12.5	12	8.5	0.16	0.09
8	14.5	15	9	0.20	0.12
10	18	18	11.5	0.30	0.16
12	22	22	12	0.40	0.26
14	24	22	12	0.50	0.34
16	27.5	25	15.5	0.63	0.36
18	30	28	14	0.80	0.49
20	34	31	17	1.00	0.62
22	37	33	17.5	1.30	0.76
25	43	33	21	1.50	0.94
30	51.5	44	23	2.30	1.5
Total Weight				9.31	5.77

1. Both Stainless steel frame and Titanium frame can be done.
2. Any ceramic ring can be chosen.
3. The color of the frame and the ceramic ring can be chosen.

1. 支架材质可选用 不锈钢或钛 材质。
2. 瓷环任选。
3. 支架与瓷环颜色任选。



OY



WO-UOYLTSG-1 WO-NOYLTSG WO-TWOYLTSG WO-BOYLTSG-2

SIZE	H	L	L1	SW
6	14	15	7	0.2
8	18	17	9	0.3
10	20	21	11	0.4
12	28	25	11.5	0.7
16	36	27	12	0.9
20	40	33	13	1.2
25	50.5	37	17	2.2
30	58	45	21	2.8

1. Stainless steel frame.
2. Any ceramic ring can be chosen.
3. The color of the frame and the ceramic ring can be chosen.

1. 不锈钢支架。
2. 瓷环任选。
3. 支架与瓷环颜色任选。



NOY



WO-TWNOYLSG WO-NOYLSG WO-UNOYLSG-1 WO-NOYLSG

SIZE	H	L	S/W
6	11	8.5	0.1
8	15	8	0.2
10	17	10.5	0.3
12	21	12	0.5
16	25	14	0.9
20	32.5	17	1.4
25	42	18.5	1.8
30	51	21	2.9

1. Stainless steel frame.
2. Any ceramic ring can be chosen.
3. The color of the frame and the ceramic ring can be chosen.

1. 不锈钢支架。
2. 瓷环任选。
3. 支架与瓷环颜色任选。



GUIDING THE FUTURE



New Titanium, High quality

Titanium is relatively important metal which developed since the 1950s. And it's used for fishing in recent years. The material we selected is alloy titanic which is used of aircraft industry, this material has improved the hardness of the guide frame, it's lighter than stainless steel. It has high corrosion proof quality and high heat proof quality. And it doesn't need to be plated, so it's environmental protection. "Ti" can satisfy the customers' demand much more.



Contrast of former and present hardness
SEA-GUIDE 导环 (钛) 拉力测试对照图

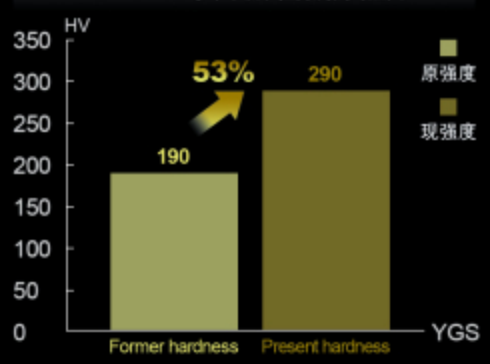

Contrast of specific gravity
SEA-GUIDE 导环材质比重对照图

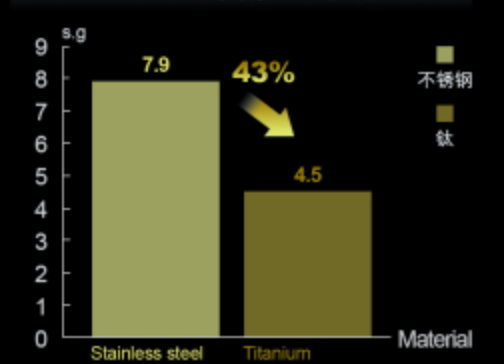

新材料，高品質

“钛”是20世纪50年代发展起来的一种重要的结构金属。近几年被应用于钓具行业。我公司目前采用应用于航空业的钛合金材料精制做导眼支架，提升了钛架导眼的强度，与不锈钢支架相比，重量减轻，耐腐蚀性好，无需电镀，更加环保，能更好地满足客户的使用需求。

YGS



WO-TUYSLGG WO-UYSLTSG-1 WO-NYSLTSG WO-GYSLTSG-4



SIZE	H	L	S/W	T/W
4	10	4	0.10	0.06
5	11.5	5	0.12	0.07
6	15.5	7.5	0.16	0.09
8	18.5	8	0.26	0.15
10	21.5	9	0.42	0.24
12	27	10.5	0.6	0.32
16	34	11.5	0.9	0.50
20	41.5	14.5	1.3	0.75
25	51.5	16	2.4	1.33
30	58	16	3.2	2.16
Total Weight			9.46	5.67

- Both **Stainless steel frame and Titanium frame** can be done.
 - Any ceramic ring can be chosen.
 - The color of the frame and the ceramic ring can be chosen.
- 支架材质可选用 **不锈钢或钛** 材质。
 - 瓷环任选。
 - 支架与瓷环颜色任选。

MHL



WO-UMHLLTSG-1 WO-TWMHLLSG WO-RMHLLTSG-2 WO-MHLLTSG

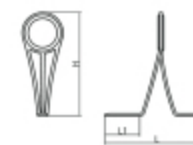

SIZE	H	L	L1	S/W	T/W
4	10.5	17	6		
5	15	24	8		
6	19	27.5	9	0.3	0.28
8	23	28	11	0.5	0.31
10	28	35	12	0.9	0.59
12	33	43	13	1.1	0.61
16	41.5	42.5	14	1.4	0.78
20	50	48	14.5	2	1.18
Total Weight				6.2	3.75

- Both **Stainless steel frame and Titanium frame** can be done.
 - Any ceramic ring can be chosen.
 - The color of the frame and the ceramic ring can be chosen.
- 支架材质可选用 **不锈钢或钛** 材质。
 - 瓷环任选。
 - 支架与瓷环颜色任选。

OH



WO-BOHLLTSG-2 WO-GOHLTSG-4 WO-OHLLTSG WO-TUOHLGG



SIZE	H	L	S/W
6	14	6.5	0.24
8	17.5	7	0.25
10	22.5	9	0.4
12	28	11	0.6
16	35	12	0.8
20	39	16	1.5
25	50	19	2.5
30	65	22	3.4

- Stainless steel frame.
 - Any ceramic ring can be chosen.
 - The color of the frame and the ceramic ring can be chosen.
- 不锈钢支架。
 - 瓷环任选。
 - 支架与瓷环颜色任选。

L



WO-BLLTSG-2 WO-ULLTSG-1 WO-NLLTSG WO-LTSG

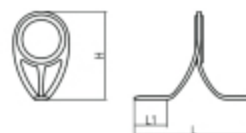

SIZE	H	L	L1	S/W
6	11	17	6	0.2
8	15	23.5	7.5	0.4
10	19	25	8	0.6
12	22	30.5	9.5	0.7
16	26.5	36	10.5	1.2
20	33	43	11	1.8
25	41.5	47	13.5	3.2
30	55	60	15.5	4.8
40	61	64	16	7.2

- Stainless steel frame.
 - Any ceramic ring can be chosen.
 - The color of the frame and the ceramic ring can be chosen.
- 不锈钢支架。
 - 瓷环任选。
 - 支架与瓷环颜色任选。

HL



WO-BHLLTSG-2 WO-HLLTSG WO-TUHLLGG WO-TWHLLSG

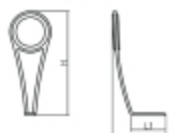

SIZE	H	L	L1	S/W
4LL	8.5	7	5	0.08
4L	9.5	10	6	0.08
4	11.5	13	7	0.09
5	15	16	8.5	0.15
6	18	17	9	0.2
8	22	20	11	0.3
10	26	24	12	0.6
12	31	28	13	0.8
16	39.5	29	14	1
20	48	33	14.5	1.4

- Stainless steel frame.
 - Any ceramic ring can be chosen.
 - The color of the frame and the ceramic ring can be chosen.
- 不锈钢支架。
 - 瓷环任选。
 - 支架与瓷环颜色任选。

B



WO-BBLTSG WO-TUBLSG WO-GBTSG WO-BTSG

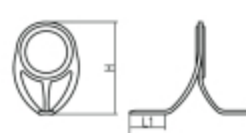

SIZE	H	L	L1	S/W	T/W
6	11.5	20	6.5	0.32	0.18
8	13	22.5	7	0.4	0.23
10	16.5	26	8	0.51	0.29
12	20	26.5	8.5	0.67	0.38
16	25.5	35	10.5	1.3	0.71
20	31.5	40	11.5	1.8	0.92
25	39.5	51	14.5	3.3	1.81
30	49	57.5	15.5	4.7	2.8
40	55	68	17	7.3	4.24
50	73.5	83.5	24	14.2	8.1
Total Weight				34.5	19.66

- Both **Stainless steel frame and Titanium frame** can be done.
 - Any ceramic ring can be chosen.
 - The color of the frame and the ceramic ring can be chosen.
- 支架材质可选用 **不锈钢或钛** 材质。
 - 瓷环任选。
 - 支架与瓷环颜色任选。

T



SIZE	H	L	L1	SW	T/W
6	11.5	20	7.5	0.25	0.14
7	13	18	7	0.29	0.17
8	14.5	22	8.5	0.33	0.19
10	18.5	26	9.5	0.53	0.3
12	22	29.5	10	0.67	0.38
14	25.5	27	10	0.9	0.51
16	26.5	33	11.5	1.1	0.63
20	32.5	41	12.5	1.7	0.91
25	42	44	13.5	2.7	1.46
30	52	51	14.5	3.6	1.98
40	60	58	17	5.4	3.16
50	82	85.5	26	13.3	7.75
Total Weight					30.77 17.58

- Both **Stainless steel frame and Titanium frame** can be done.
- Any ceramic ring can be chosen.
- The color of the frame and the ceramic ring can be chosen.

- 支架材质可选用 **不锈钢或钛** 材质。
- 瓷环任选。
- 支架与瓷环颜色任选。



OB

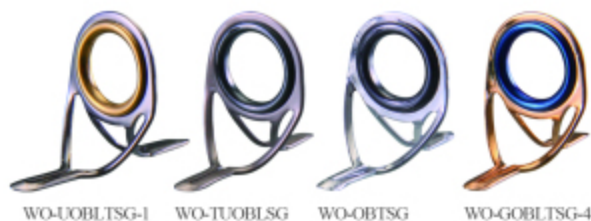

SIZE	H	L	L1	S/W
6	10.5	19.5	6.5	0.2
8	13	24	8	0.4
10	18	27	8.5	0.5
12	20	31	9	0.7
16	26	39.5	12	1.5
20	32.5	45.5	13.5	2
25	42	51	15	2.3
30	53	58	16	4.8
40	62	74	22	7.5
50	76	94	22	11.4

- Stainless steel frame.
- Any ceramic ring can be chosen.
- The color of the frame and the ceramic ring can be chosen.

- 不锈钢支架。
- 瓷环任选。
- 支架与瓷环颜色任选。

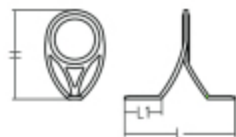

U



SIZE	H	L	L1
8	14.5	24	6
10	18	30	8
12	21	37	10
16	28	45	12
20	35	52.5	13
25	44.5	65	14
30	49.5	80	18

- Copper frame.
- It need thick ring like "TSW,ESW", and so on.
- The color of the frame and the ceramic ring can be chosen.

- 铜支架。
- 需配厚瓷环，如 "TSW,ESW"等。
- 支架与瓷环颜色任选。

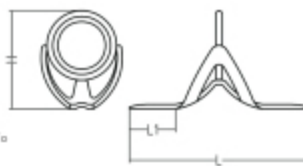

LR



SIZE	H	L1	L2	L3	SW
8	15	7.5	7	30.5	1.1
10	18.5	9	8.5	36	1.8
12	22	11.5	10.5	41.5	2.9
16	28	16	12.5	54	5.5
20	36	18	15	67	12.1
25	50	20	19	82	17.9

- Stainless steel frame.
- It need thick ring like "TS,ES", and so on.
- The color of the frame and the ceramic ring can be chosen.

- 不锈钢支架。
- 需配厚瓷环，如 "TS,ES"等。
- 支架与瓷环颜色任选。

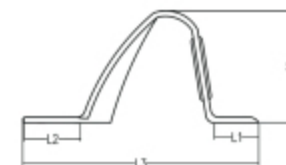

XB



SIZE	H	L	L1	L2	SW	T/W
6	11	19	4.5	6	0.28	0.16
8	14	21	4.5	6.5	0.4	0.23
10	17	27	5	7	0.6	0.35
12	21	28	6.5	7.5	0.8	0.48
16	27	36	8	10	1.1	0.99
20	31	48	10	12	1.8	1.35
25	40	61	13.5	14.5	3.5	2.33
30	50	72	17.5	19	6.1	3.32
40	60	82	20	22	8.2	5.46
50	75	85	20	21	14.5	8.36
Total Weight						37.28 23.03

- The frame encasing the ring is broadrimmed,so it can effectively avoid the ring broken off.
- Both **Stainless steel frame and Titanium frame** can be done.
- Any ceramic ring can be chosen.
- The color of the frame and the ceramic ring can be chosen.

- 包覆式支架，能有效防止瓷环的脱落。
- 支架材质可选用 **不锈钢或钛** 材质。
- 瓷环任选。
- 支架与瓷环颜色任选。



XT



SIZE	H	L	L1	L2	L3	S/W	T/W
6	11	14	3.5	4.5	4.5	0.15	0.09
8	14.5	18.5	4	6	6.5	0.28	0.16
10	18.5	20.5	5.5	7.5	8.5	0.47	0.27
12	22	24	6.5	8.5	9.5	0.65	0.37
16	26.5	32.5	8.5	10.5	13	1.19	0.68
20	33.5	39.5	10	13	16.5	1.6	0.92
25	43.5	48	13.5	16	18	3.1	1.66
30	53	61.5	17	21	25	4.8	2.8
40	60	66	18	22	26.5	8.1	4.24
50	80	86.5	22	25	34	10.5	5.92
Total Weight							30.84 17.11

- The frame encasing the ring is broadrimmed, so it can effectively avoid the ring broken off.
- Both **Stainless steel frame and Titanium frame** can be done.
- Any ceramic ring can be chosen.
- The color of the frame and the ceramic ring can be chosen.

- 包覆式支架，能有效防止瓷环的脱落。
- 支架材质可选用 **不锈钢或钛** 材质。
- 瓷环任选。
- 支架与瓷环颜色任选。



XE



SIZE	H	L	L1	S/W
8	14	34	7.5	0.7
10	17	41	9	1
12	18	50	10.5	1.8
16	27	64	13.5	3.7
20	46	91	16.5	8.5

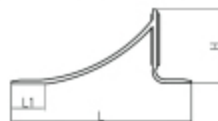

1. The frame encasing the ring is broadbrimmed, so it can effectively avoid the ring broken off.
2. Stainless steel frame
3. "O" ring.
4. The color of the frame and the ceramic ring can be chosen.

1. 包覆式支架, 能有效防止瓷环的脱落。
2. 不锈钢支架。
3. "O" 环。
4. 支架与瓷环颜色任选。

XR



SIZE	H	L	L1	L2
8	14	25	6.5	6.5
10	18	30.5	8	8
12	23	38.5	9	10
16	28	50	12	13
20	35	60	15	17
25	51	80	19	20

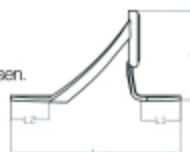

1. The frame encasing the ring is broadbrimmed, so it can effectively avoid the ring broken off.
2. Stainless steel frame.
3. It need thick ring like "TS,ES", and so on.
4. The color of the frame and the ceramic ring can be chosen.

1. 包覆式支架, 能有效防止瓷环的脱落。
2. 不锈钢支架。
3. 配厚瓷环, 如 "TS,ES" 等。
4. 支架与瓷环颜色任选。

AG

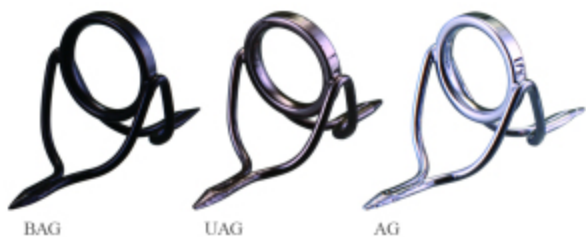

SIZE	H	L	L1
8	14	35	11
10	14.5	35	11
12	19	37	11
14	21	40	12
16	22	46	12
18	25	50	13
20	28	56	14.5
25	35	60	15
30	42	73	19



1. Both Stainless steel frame and tungsten steel frame can be done.
1. 导环圈可选用不锈钢或钨钢。

BG



SIZE	H	L	L1
8	13	32.5	11
10	15	36.5	11
12	18	40.5	11
16	22	47	12
20	28	55	14.5
25	35	60	15
30	43	70	19



MK



SIZE	H	L	L1
3.5	4.5	8.0	6
4	5.5	8.5	6
4.5	6.5	9.5	7
5	7.5	11.5	8.5
5.5	8.5	12.0	9.5
6	9.5	14.0	10.0
6L	10.5	15.0	10.0
7	10.5	15.5	11.5
8	12.0	18.0	12.0
8L	14.0	18.0	12.0
10	13.5	19.0	13.5

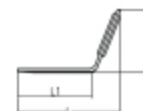

XM



SIZE	H	L	L1
4	5.0	7.5	5.5
5	6.5	9.5	7.0
5L	8.5	10	7.0
6	8.5	10.0	7.0
6L	9.5	10.5	7.0
7	10.0	12.0	8.0
7L	11.5	13.0	8.0
8	11.5	13.5	8.5
8L	13.5	15.0	8.5



1. The frame encasing the ring is broadbrimmed, so it can effectively avoid the ring broken off.
2. Both Stainless steel frame and Titanium frame can be done.
3. Any ceramic ring can be chosen.
4. The color of the frame and the ceramic ring can be chosen.

1. 包覆式支架, 能有效防止瓷环的脱落。
2. 支架材质可选用 不锈钢或钛 材质。
3. 瓷环任选。
4. 支架与瓷环颜色任选。

SV



SIZE	H	W
6	13	8
8	14.5	8
10	18.5	8
12	21	8
16	25.5	10
20	32.5	10
25	38.5	12
30	48.5	14
40	59	16
50	66	18



Y



WO-UYLTSG-1 WO-TWYLSG WO-NYLTSG WO-BYLTSG-2

SIZE	H	W
8	15.5	8
10	19	8
12	23	10
16	27	12
20	35	12
25	42	14
30	53	16
40	60	18

OSFR



WO-TUOSFRLGG WO-UOSFRLTSG-1 WO-BOSFRLTSG-2 WO-OSFRISG

SIZE	H	W	SIZE	H	W
4	7	8	14	24	10
5	10.5	8	16	27.5	10
6	11	8	18	30	10
7	12.5	8	20	34	10
8	14.5	8	22	37	12
10	18	8	25	43	12
12	22	8	30	51.5	14

HM



WO-HMTSG WO-UHMLTSG-1
WO-BHMLTSG-2 WO-TUHMLGG

SIZE	I/D	W	H	SIZE	I/D	W	H
7	1.2	5	14.2	12	6.7	7.5	28
	1.5				7		
	1.7	5	15.2		7.2		
	2				7.5		
	2.2				7.7		
	2.5				8		
8	2	6	17.8		8.2		
	2.2				8.5	8	29.7
	2.5				8.7		
	2.7				9		
	3				9.2		
	3.2				9.5		
	3.5	6	19.5		9.7		
	3.7				10		
	4				10.2	8	31.3
	4.2				10.5		
	4.5				10.7		
	4.7				11		
	5				11.2		
10	3.7	7	22.2		11.5		
	4				11.7		
	4.2			16	10.7	8.5	35.3
	4.5				11		
	4.7				11.2		
	5				11.5		
	5.2	7	23.5		11.7	8.5	37
	5.5				12		
	5.7				12.5		
	6				13	8.5	38.8
	6.2				13.5		
	6.5				14		
12	5.2	7.5	26.8		14.5	10	40.5
	5.5				15		
	5.7				15.5		
	6				16	10	42.3
	6.2				16.5		
	6.5				17		

SM



WO-BSMLTSG-2 WO-TUSMLTSG-1

SIZE	I/D	W	H
4	1.8-2.4	6	12.8
5	1.8-2.4	6	15
	2.5-3.4	6.4	16
6	1.8-2.4	6	16
	2.5-3.4	6.4	17
	3.5-4.2	7	18.5
8	1.8-2.4	6	18
	2.5-3.4	6.4	18.5
	3.5-4.2	7	19.8
	4.3-5.5	7.7	21.5

SIZE	I/D	W	H
10	1.8-2.4	6	20.5
	2.5-3.4	6.4	22
	3.5-4.2	7	22.8
	4.3-5.5	7.7	24
	5.6-6.9	8.4	26
12	4.3-5.5	7.7	26
	5.6-6.9	8.4	28
	7.0-8.5	9	29.8
	8.6-10.7	9.2	32.8
	5.6-6.9	8.4	33
	7.0-8.5	9	34.5
	8.6-10.7	9.2	37
	10.8-12.2	10	41
20	8.6-10.7	9.2	42.5
	10.8-12.2	10	44.5
	12.3-14.7	11.6	47



WO-TUSMLTSG WO-SMTSG

WDM



WO-UWDMIDG-1 WO-BWDMIDG-2

SIZE	I/D	W	H
5	1-1.5	4	10
	1.6-2.2	4.2	11
	2.3-3	4.4	12
	3.1-4	4.4	13
	4.1-5	5.2	14.5
	5.1-6.3	5	16
	6.4-8	6	18.5
5.5	5.1-6.3	5	17
6	6.4-8	6	19.5
	8.1-9.2	6.3	21

SIZE	I/D	W	H
6	9.3-10.3	6.8	22
	10.4-11.2	6.7	23
	11.3-12	6.5	24
	12.1-13.4	6.8	25
8	10.4-11.2	6.6	26
	11.3-12	7	27.5
	12.1-13.4	7	28
	13.5-14.6	7.5	29.5
	14.7-15.8	7.6	30.5
	15.9-17.5	8.3	32.5
10	15.9-17.5	8.7	36
	17.6-18.5	8.3	36
	18.6-19.3	9	37
	19.4-20.6	9.1	38
	20.7-21.4	9.7	39
	21.5-22.1	10.5	40
12	21.5-22.1	10.2	43
	22.2-24.6	10.3	44.5



WO-TWWDMLSG WO-WDMTSG

MV



WO-NMVLTSG WO-MVTSG WO-UMVLTSG-1 WO-BMVLTSG-2

SIZE	H	W
6	14.5	8
8	15.5	8
10	19	8
12	22	8
16	29.5	10
20	34	10
25	42.5	12
30	52.5	14
40	57.5	16

WM



WO-UWMIDG-1

SIZE	I/D	H	W	SIZE	I/D	H	W
4	1.5-2.6	14.7	6.4	10	3.7-4.4	22.5	6.5
5	1.5-2.6	14.7	6.4		4.5-5.8	24	7.7
	2.7-3.6	15.9	6.5		5.9-7.1	27.6	8.4
6	1.5-2.6	15.8	6.4	12	4.5-5.8	26	8
	2.7-3.6	16.8	6.4		5.9-7.1	28	8
	3.7-4.4	18.2	6.4		7.2-8.7	29.5	9
8	1.5-2.6	18	6.1		8.8-10.9	33	9.4
	2.7-3.6	18.5	6.3	16	4.5-5.8	31	8
	3.7-4.4	19.7	6.5		5.9-7.1	33	8
	4.5-6.0	21.3	7.7		7.2-8.7	34.5	9
10	1.5-2.6	20.5	6.2		8.8-10.9	37	9
	2.7-3.6	22	6.4		11-13.2	41	10
				20	9.1-10.9	42.5	9.7
					11-13.2	45	9.8
					13.3-15.3	47	9.8
					15.4-17.5	50	10
					17.6-19.6	52	10
				25	11.0-13.2	51	9.8
					17.6-19.6	59	10
					19.7-21.7	61	10.8
					21.8-24.1	63	11.7
					24.2-27.2	65	11.6



WO-WMTSG



WO-BWMIDG-2



WO-TUWMTSG



WFM



WO-BWFM TSG



WO-WFM TSG



WO-UWFM TSG

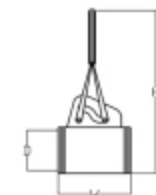

SIZE	H	W	D
25	1 76	30	16-18.4
	2 78		18.5-20.4
	3 80		20.5-22.4
	4 82.5		22.5-24.9
	5 85		25-27.4
30	1 82.5	30	16-18.4
	2 84.5		18.5-20.4
	3 86.5		20.5-22.5
	4 89		22.5-24.9
	5 91.5		25-27.4
40	1 89	30	16-18.4
	2 91		18.5-20.4
	3 93		20.5-22.4
	4 95.5		22.5-24.9
	5 98		25-27.4

WF



WO-TUWF TSG



WO-WF TSG



SIZE	H	L	L1
25	59	54	14.3
30	64.5	54	14.3
40	71	54	14.3
50	86	54	14.3

S'SG



SIZE	Ø	Ø1	L1	L	H
4	4	0.7	8	19	5
5	5	0.7	8.5	20	6
5.5	5.5	0.7	9	21	6.5
6	6	0.8	9.5	22	8
6.5	6.5	0.8	10	24	9
7	7	1	11	26	9.5
8	8	1	12	28	10.5
8.5	8.5	1.2	14	30	11.5

ZHOOK



SIZE	H	W	L	L1	SW	TW
6	7.5	4.5	8	17	4.5	17.3

HOOK

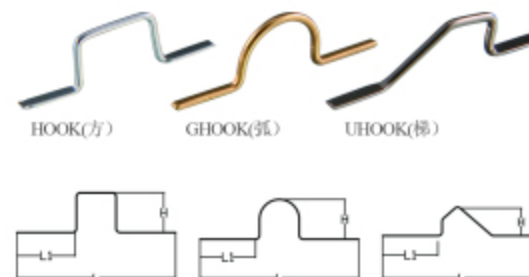

SIZE 梯形	H	L	L1
6	4.5	23	5.5

SIZE 弧形	H	L	L1
4	5.5	15.5	5
5	6	18	5
6	6.5	21.5	6.2

SIZE 方形	H	L	L1
5	6	17	5
6	6.5	23	6.5

H.HOOK



SIZE	H	L	L1
8	8	28	12
10	10	28	12
12	12	28	12

NRHG



SIZE	H	L	L1
1	23	55	13
2	30.5	72	16
3	37.5	87	19

RHG



SIZE	H	L1	L2	L
1	22.5	12	17	67
2	26	14	19	79.5
3	30	16	21	90.5

XPHG



SIZE	H	L	L1
8	19.5	50	11.5
10	25.5	61	13.5
12	30	71.5	15.5
14	36.5	88.5	20
18	52.5	121	24.5

ICFG



SIZE	L	L1	L2	H
	80	12	12	10

XSFG



SIZE	Ø	Ø1	H	L
4	4	0.7	5	8
5	5	0.7	6	9
6	6	0.8	7.5	10
7	7	1	9	11
8	8	1	10.5	12
10	10	1.2	12.5	13

XL

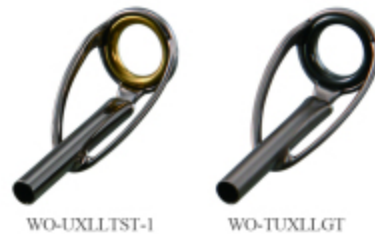

SIZE	H	L	D	SIZE	H	L	D
4	6	12	0.7	7	10	21	2
			0.8				2.2
			0.9				2.4
			1				2.6
			1.1				2.8
			1.2	8	11.2	25	1.6
			1.3				1.8
			1.4				2
			1.5				2.2
5	6.8	15	0.8				2.4
			0.9				2.6
			1				2.8
			1.1				3
			1.2				3.2
			1.3	10	16.5	27	1.6
			1.4				1.8
			1.5				2
			1.6				2.2
			1.8				2.4
6	9	18	1				2.6
			1.1				2.8
			1.2				3
			1.3				3.2
			1.4				3.6
			1.5				4
			1.6	12	17.5	28	2.2
			1.8				2.4
			2				2.6
			2.2				2.8
			2.4				3
7	10	21	1.2				3.2
			1.4				3.6
			1.6				4
			1.8				4.5

1. The frame encasing the ring is broadbrimmed, so it can effectively avoid the ring broken off.
 2. Both Stainless steel frame and Titanium frame can be done.
 3. Any ceramic ring can be chosen.
 4. The color of the frame and the ceramic ring can be chosen.
1. 包覆式支架，能有效防止瓷环的脱落。
2. 支架材质可选用 不锈钢或钛 材质。
3. 瓷环任选。 4. 支架与瓷环颜色任选。

V



SIZE	L	H	D	SIZE	L	H	D
6	21	8.5	1	8	26	12	3
			1.2				1.8
			1.4				2
			1.6				2.2
			1.8				2.4
			2				2.6
			2.2				2.8
			2.4				3
8	26	12	1.6				3.2
			1.8	12	41.5	16	2.2
			2				2.4
			2.2				2.6
			2.4				2.8
			2.6				3
			2.8				3.2

XS



WO-TUXSLGT WO-XSTST



WO-TWXSLSLST WO-BXSLSLST

SIZE	H	L	D	SIZE	H	L	D
5	8.5	19	1.2	8	12	26	3
			1.4				3.2
			1.6				3.6
			1.8				4
			2				4.4
6	11	20	1.2	10	16	31	1.8
			1.4				2
			1.6				2.2
			1.8				2.4
			2				2.6
8	12	26	1.6	12	20	35	2.2
			1.8				2.4
			2				2.6
			2.2				2.8
			2.4				3
			2.6				3.2
			2.8				3.6
			3				4
			3.2				4.4
			3.6				4.8

1. The frame encasing the ring is broadbrimmed, so it can effectively avoid the ring broken off.
2. Both Stainless steel frame and Titanium frame can be done.
3. Any ceramic ring can be chosen.
4. The color of the frame and the ceramic ring can be chosen.

1. 包覆式支架，能有效防止瓷环的脱落。
2. 支架材质可选用 不锈钢或钛 材质。
3. 瓷环任选。
4. 支架与瓷环颜色任选。

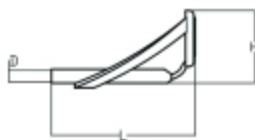

SL



WO-NSLLTST WO-GSLLTST-4 WO-SLST WO-TWSLST

SIZE	L	H	D
3.5	14	6.5	0.8
			1
			1.2
			1.4
			1.6
4	20	10	0.8
			1
			1.2
			1.4
			1.6
5	24	11	1.6
			1.8
			2
			2.2
			2.4
6	24	12	1.8
			2
			2.2
			2.6
			3

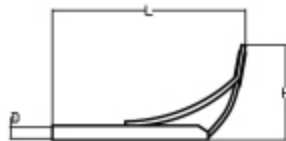

L



WO-ULLTST WO-BLLTST WO-LLTST

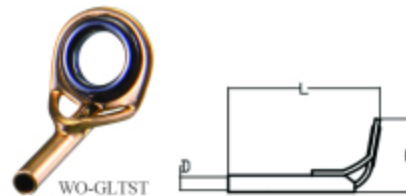

WO-GLTST

SIZE	L	H	D	SIZE	L	H	D
5	15.5	6	0.8	6	16	8	2
			0.9				2.1
			1				2.2
			1.2				2.4
			1.3				2.6
6	16	8	1.2	8	18	10	1.8
			1.4				2
			1.5				2.2
			1.6				2.4
			1.8				2.6
			2				2.8
			2.2				3.2
			2.4				3.6
			2.6				4
			2.8				4.4

S



WO-BSDT-3



WO-STST



WO-GSTST



SIZE	L	H	D	SIZE	L	H	D
5	16.5	9.5	1	10	29	16.5	3.2
			1.2				3.6
			1.4				4
			1.6				4.4
			1.8				4.8
6	17	12	1	12	33	19	2.2
			1.2				2.4
			1.4				2.6
			1.6				2.8
			1.8				3
			2				3.2
			2.2				3.6
			2.4				4
			2.6				4.4
			2.8				4.8
8	24	13.5	1.6	14	39	21	2.8
			1.8				3
			2				3.2
			2.2				3.4
			2.4				3.6
			2.6				3.2
			2.8				3.6
			3				4
			3.2				4.4
			3.6				4.8
10	29	16.5	1.6	16	40	22	2.8
			1.8				3
			2				3.2
			2.2				3.4
			2.4				3.6
			2				3.2
			2.2				3.6
			2.4				4
			2.6				4.4
			2.8				4.8
			3				5.5
			3.2				6
			3.4				6.4
			3.6				6.8
			3.8				7.2

U



SIZE	L	H	D	SIZE	L	H	D
8	26	12	2.4	10	35	13.5	2.6
			2.6				2.8
			3				3
			3.2				3.2
			3.6				3.6
			4				4
							4.5
							5
	12	40	18.5				3.2
							3.6
							4
							4.5
							5
							5.5
							6



LR



SIZE	L	H	D
10	43	20	2.6
			2.8
			3
			3.2
			3.6
			4
			4.5
			5
12	54	23	3.2
			3.6
			4
			4.5
			5
			5.5
			6



AT-1

SIZE	L	H	D
8	26	16	任选
10	30	17	
12	38	18	

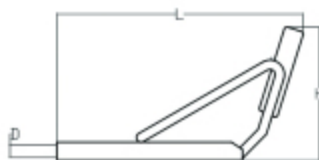

AT-2

SIZE	L	H	D
8	32	16	任选
10	34	16	
12	36	20	

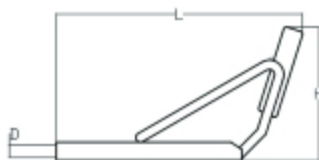

MK

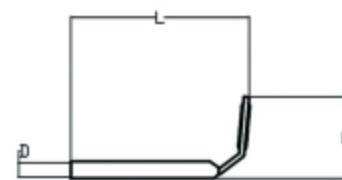

SIZE	L	H	D	SIZE	L	H	D
3.5	13.5	7	0.8	5	15	8	1
		0.9					1.1
		1					1.2
		1.2					1.3
		1.4					1.4
4	14	7	0.8				1.5
		0.9					1.6
		1					1.8
		1.1		6	15.5	8	1
		1.2					1.1
		1.3					1.2
		1.4					1.4
		1.5					1.6
4.5	14.5	7	0.8				1.8
		0.9					2
		1					2.2
		1.2					2.4
		1.3		8	15.5	11	1.6
		1.4					1.8
		1.5					2
5	15	8	0.8				2.2
		0.9					2.4

XR

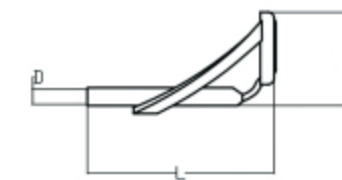

1. The frame encasing the ring is broadbrimmed, so it can effectively avoid the ring broken off.
2. Both Stainless steel frame and Titanium frame can be done.
3. Any ceramic ring can be chosen.
4. The color of the frame and the ceramic ring can be chosen.

1. 包覆式支架，能有效防止瓷环的脱落。
2. 支架材质可选用 不锈钢或钛 材质。
3. 瓷环任选。
4. 支架与瓷环颜色任选。

SIZE	L	H	D
8	26	13	2.4
			2.6
			3
			3.2
			3.6
			4
10	33	15	2.6
			2.8
			3
			3.2
			3.6
			4
			4.5
			5
			3.2
			3.6
12	40	18	4
			4.5
			5
			5.5
			6

BT



BBT BT TUBT UBT

SIZE	H	L	D
8	19	14	任选
10	23	14	
12	32	18	
16	35	25	



FWT



UFWT FWT GFWT



SIZE	Ø	d	L	H	D
4	4	0.7	20.5	5.6	任选
5	5	0.7	21	6.5	
6	6	0.8	21	8.5	
7	7	1	21.5	9	
8	8	1	22	10	
10	10	1.2	22	13	

NRHT



NRHT UNRHT BNRHT

SIZE	H	L	L1	d
10	54	32	任选	

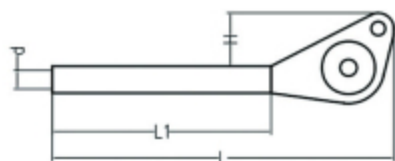

DRHT



BDRHT UDRHT DRHT

SIZE	H	L	L1	d
16	64	32	任选	

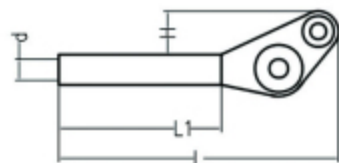

RHT



RHT URHT BRHT



SIZE	H	L	L1	d
19	54	30	≤7	

IHFG



SIZE	L	L1	L2	H
80	13.5	13.5	20	

ITHT

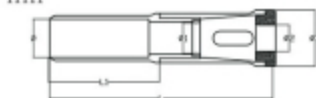

SIZE	Ø	Ø1	Ø2	Ø3	L	L1
6	2.4-3.5	1.8	3	7.3	27	14
8	2.8-4.4	2	4.6	9.4	32	17
8	4.5-6	2.9	4.6	9.4	32	17
10	4.5-5.5	2.9	6	11.8	38	21
10	5.6-6.5	3.9	6	11.8	38	21

XPHT



XPHT BXPHT UXPH



SIZE	L	L1	L2	I/D
87	68	24	任选	

ITSG



SIZE	L	L1	L2	H	H1
92	11	11	10.5	7	

ITST



SIZE	Ø	Ø1	Ø2	L
6	1.6-4.5	3	7.3	25
8	2.8-5.6	4.6	9.4	27.5
10	3.6-6.5	6	11.8	34

XCKS



NEW

SIZE	O/D1	O/D2	I/D1	L
16	18.5	25.5	15.5	153

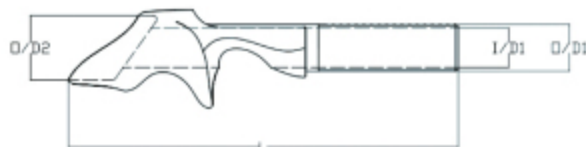

XKS



NEW

SIZE	O/D1	O/D2	I/D1	L
16	18.5	25.5	15.5	142

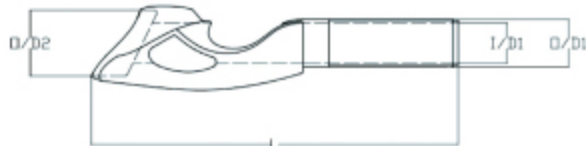

XIS



NEW

SIZE	O/D1	O/D2	I/D1	L
16	18.5	19.6	15.5	120



XCIS



SIZE	O/D1	O/D2	O/D3	I/D1	L	L1
16	18.5	28	23	15.2	133	8



DNPS



DNPS DNPS-SNL ADNPS

SIZE	O/D1	O/D2	I/D1	L
16	18.4	23	15.5	125
18	20.8	25.7	18.2	131
20	22.9	27.7	20.2	131



XCHS



SIZE	O/D1	O/D2	O/D3	I/D1	L	L1
16	18.5	28	22.5	15.2	130	18

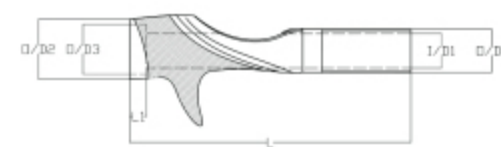

XHS



SIZE	O/D1	O/D2	O/D3	I/D1	L	L1
16	18.5	28	23	15.2	135	20

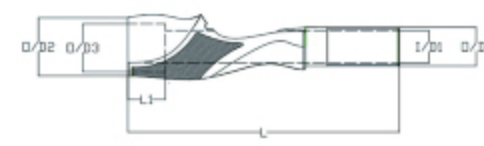

XCJS



SIZE	O/D1	O/D2	O/D3	I/D1	L	L1
16	18.5	26	17.5	15.2	135	18





XJS



SIZE	O/D1	O/D2	O/D3	I/D1	L	L1
16	18.5	26	17.5	15.2	121	18

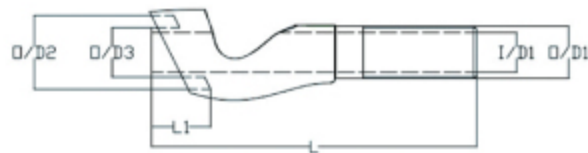

DPS



SIZE	I/D1	O/D2	O/D1	L
16	15.5	21.8	18.4	106
18	18	24.5	21	126
20	20	26.5	22.8	130
22	22	28.4	24.8	129
24	24	31	27.2	138
26	26	33	28.8	138
28	28	35	30.8	138

PM-DPS PM-DPS DPS X-DPS

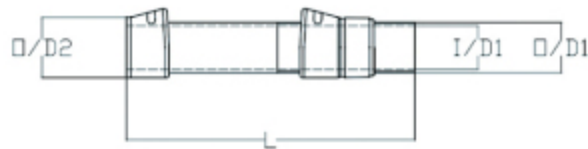

NPS



SIZE	O/D1	L1	I/D1	O/D2	L
16	17.7	44	15.5	18.3	132
18	20.7	54	18.2	21	151
20	22.7	60	20	22.8	161
22	24.7	60	22.2	24.8	161
24	26.8	60	24.2	27.2	161
26	28.8	60	26.4	28.8	161

NPS K-NPS NPS-L



TPS



SIZE	O/D2	I/D1	O/D1	L	O/D3	L1
16	27	9.5-15.5	18.5	108	22.8	10
18	26	18.2	21	125	22.8	7

TPS TPS-N



ECS



SIZE	O/D1	L1	L	O/D3	O/D2	I/D1
16	18.5	10	108	23	28	95-155

K-ECS ECS-N ECS



IPSA



SIZE	I/D	O/D1	O/D2	O/D3	L	L1
16	9.0-15.5	28	18.5	17.5	108	46
18	18	30	21	20	118	51

K-IPSA IPSA IPSA-NLL





IPSB



SIZE	O/D1	O/D2	O/D3	I/D1	L	L1	L2
16	18.5	27	22.8	9.5-15.0	108	8	54

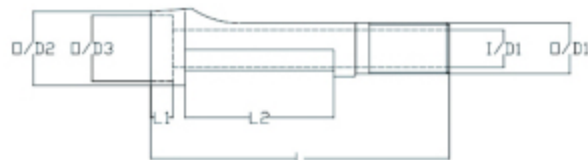

PS



SIZE	L	L1	L2	L3
6	139	14	7.5	14
7	152	15	7.5	15



XPS



SIZE	L	L1	内孔锁紧范围
20	205	125	18.9-19.5
22	205	125	20.5-21.5
24	222	143	22.5-23.5
26	222	143	24.5-25.5



NPLS



SIZE	O/D1	O/D2	I/D1	L
18	20	20	18.2	168
20	22	22	20.2	168



XPLS

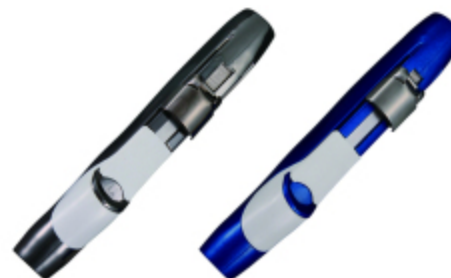

SIZE	I/D1	O/D2	O/D1	L
18	18	20	20	160
20	20	22	22	160

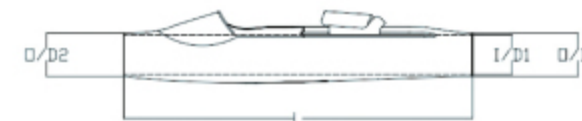

SPLS

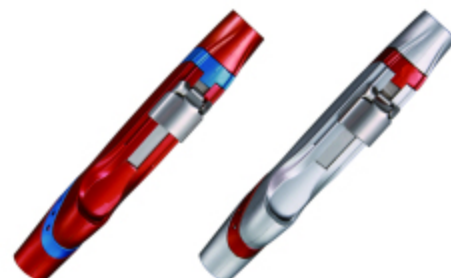

SIZE	O/D1	O/D2	I/D1	L
19	20.8	21	19	172



SECS



SIZE	I/D1	O/D1	O/D2	L
16	15.2	18.5	28	117





STPS



SIZE	I/D1	O/D1	O/D2	L
16	15.2	18.5	27.8	117



XCES



SIZE	I/D	O/D1	O/D2	L
16	15.5	18.5	28	109

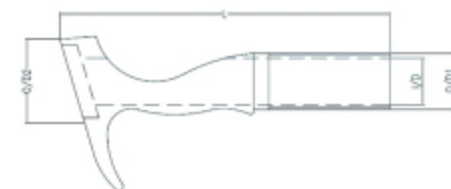

TCS



SIZE	I/D	O/D1	O/D2	L
16	15.5	18.5	27.2	115
17	17.2	20	27.2	126
18	18.2	21	27.2	136



PSS



SIZE	I/D	O/D1	O/D2	L
20	20.2	23	28	156

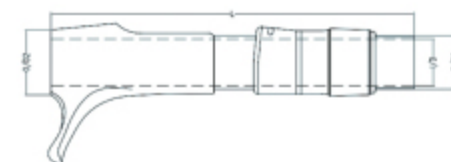

XES



SIZE	I/D	O/D1	O/D2	L
16	15.5	18.5	28	115

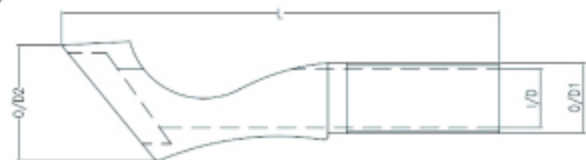

XDS



SIZE	O/D1	O/D2	I/D1	L
16	18.5	26.5	15	122



XCDS



SIZE	O/D1	O/D2	I/D1	L
16	18.5	26.5	15	122

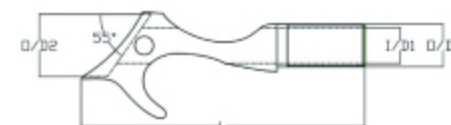



XCS



SIZE	O/D1	O/D2	O/D3	I/D1	L	L1
16	18.5	27	24	15.5	122	7

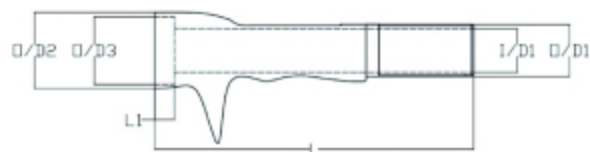

XGS



PM-XGS (螺母带响)

SIZE	I/D	O/D1	O/D2	O/D3	O/D4	L	L1
14	13.5	16.5	28	20.8	28	112	33

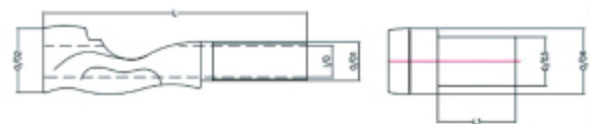

XCGS



PM-XCGS (螺母带响)

SIZE	I/D	O/D1	O/D2	L
14	13.5	16.5	28	112

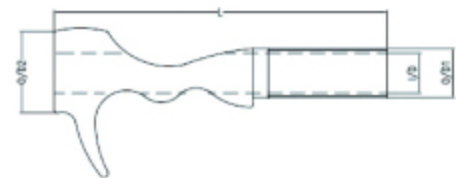

PBS

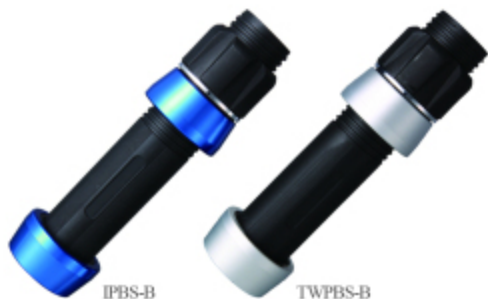

IPBS-B

TWPBS-B

SIZE	L	O/D1	O/D2	I/D1
22	135	26	33	22.4
24	140	28	35	24.4

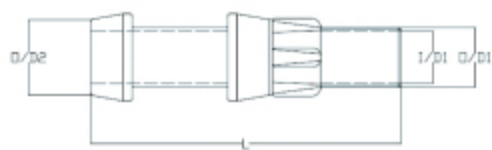

木头种类

Kinds of wood



SIM-珍珠米 BHL-玛瑙石 BYM-象牙白 XBL-雀眼木

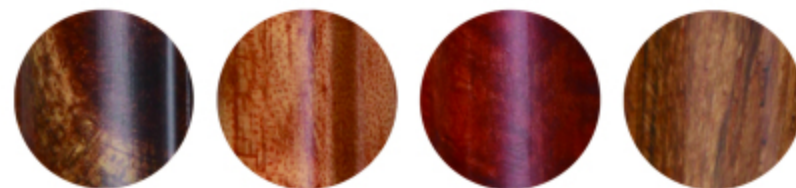

NML-绿孔雀 LYM-棕斑木 NMR-红孔雀 HT-棕黑檀



BH-花梨棕 SB-松梨木 YH-玫瑰木 GD-花榆木

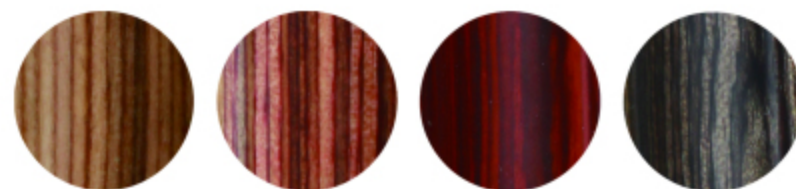

F-黄压缩木 R-红压缩木 R2-喷漆红压缩木 B-黑压缩木

TiFS



SIZE	O/D1	O/D2	I/D1	L	L1
18	19.4	17.8	16	100	12



UFS



SIZE	O/D1	L2	L1	L3	O/D2	I/D
18	19.5	35	95	11.5	17.8	<11.5
20	21.5	35	95	11.5	19.5	<13.5

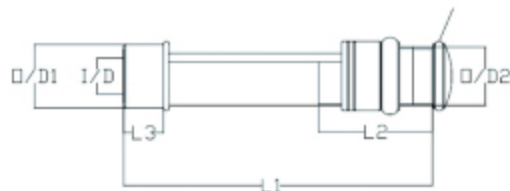

SBI-GUFS-F-HC NMR2-UFS-H XBL1-UUFS-F

IFS



SIZE	O/D1	L2	L1	L3	O/D2	I/D
18	22	40	100	8	17.8	<10
20	23	40	100	8	19.8	<11.5

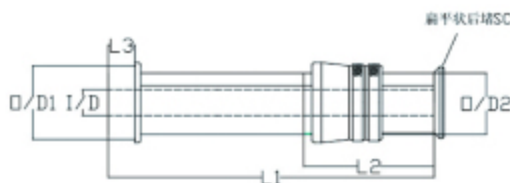

GD2-PIFS-D R-BIFS-E BH11-IFS-A-SC

CFS



XBL2-BCFS GCFS



SIZE	O/D1	O/D2	I/D1	L
18	17.8	20.5	<11.5	100
20	19.4	22	<12	100
22	21.4	24	<14.5	100

TFS



T1-UTFS-D(W) R1-UTFS-A(W) B1-TFS-A-SC

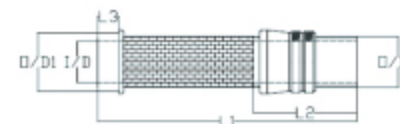

SIZE	O/D1	L2	L1	L3	O/D2	I/D
18	22	40	100	8	17.8	14
20	23	40	100	8	19.5	16

SWS



NML1-PSWS (所有尺寸可以按图纸制作)

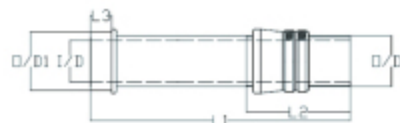

SIZE	O/D1	L2	L1	L3	O/D2	I/D
18	22	40	100	8	17.8	15/16两种
20	23	40	100	8	19.5	16/17.5两种

AFS



X2-UAFS-R

BYM1-X1-UAFS-P

X-UAFS-A

DAS



B-UDAS-B

U-UDAS-1

SIZE	O/D1	I/D1	L
16	18.5	15	140
18	21	17.2	160
20	23	19	170
22	25	21	170
24	27	23	170



DWAS



F2-P-DWAS

SIZE	O/D1	O/D2	L	L1	L2	I/D1
16	18.5	21.8	102	37	50	<12
18	21	24.5	119	39	62	<14
20	23	26.5	123	39	64	<16
22	25	28.4	125	39	64	<18

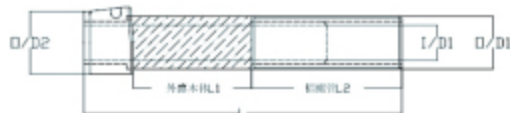

MBS



B-GMBSE

PMBSA

SIZE	O/D2	O/D1	L1	I/D
20	25.8	31	137	22.2
24	27.8	33	137	24.2
26	29.8	35	137	26.2

MBS

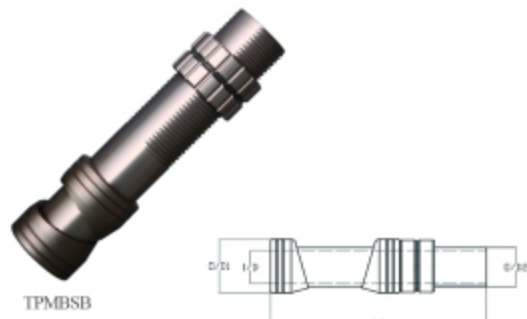

TPMSB

SIZE	O/D2	O/D1	L1	I/D
22	25.8	33.4	137	20.6
24	27.8	35.4	137	22.6

备注：内孔I/D与O/D1，O/D2轴径偏移1MM，具体见实物

DAPS



B-G-GDAPS-3

U-UDAPS-1

SIZE	O/D1	O/D2	I/D1	L
16	18.4	21.8	15.5	106
18	21	24.5	18	126
20	22.8	26.5	20	130
22	24.8	28.4	22	130
24	27.2	31	24	138
26	28.8	33	26	138

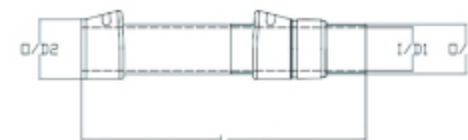

MHS



SIZE	O/D1	O/D2	I/D1	L	L1
17	19.4	26.6	17.5	105	50
19	21.4	28.6	19.3	105	50



DWPS



BHL1-DWPS

SIZE	I/D1	O/D1	L	L1
16	<12.5	18.4	130	30
18	<14.5	21	150	30
20	<16.5	22.8	150	30

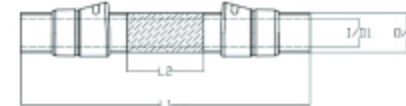

HDPS



B2-HDPS

SIZE	I/D1	O/D2	O/D1	L1	L2
16	<12.5	21.8	18.4	106	47
18	<14.5	24.5	21	125	62
20	<16.5	26.5	22.8	130	64

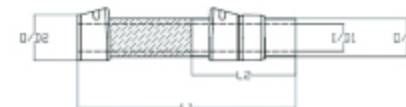



后堵



UHC



USC



UFC

五金件



BACD



TU-RACD



V-TUACD



BARC



ARC



TPACP



RACP



ACP



PARW



GARW



UARW



UAP



UAP



RAP



TPACN



TPACN



UACN



興生產